

A Summer Guide For Students Entering Pre-Algebra

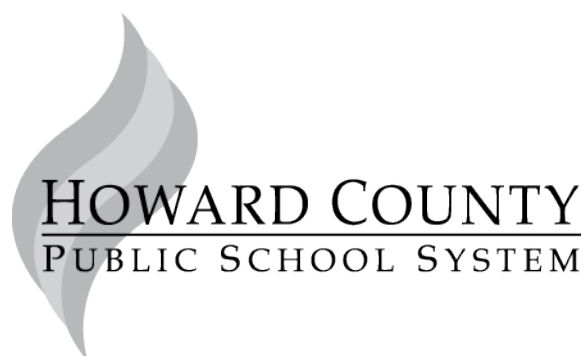

Board of Education of Howard County

Frank Aquino
Chairman

Ellen Flynn Giles
Vice Chairman

Larry Cohen

Allen Dyer

Sandra H. French

Patricia Gordon

Janet Siddiqui

Sydney L. Cousin
Superintendent of Schools

Copyright 2010

The Howard County Public School System
Ellicott City, Maryland 21042

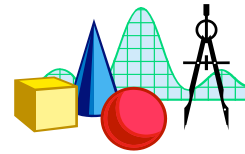

INTRODUCTION

Teachers and administrators in the Howard County Public School System actively encourage parents and community members to engage in children's learning. This guide *A Summer Guide for Students Entering Pre-Algebra* has been developed to assist friends, family, school system and community members as a resource in working together to help students reach their full potential.

- The booklet has been designed to provide practice of the mathematics knowledge needed by students entering Pre-Algebra. The Howard County Office of Mathematics suggests that students complete this booklet during the summer to maintain mathematics skills and knowledge. Completion of this booklet over the summer, though optional, will be of great value to helping students successfully meet the academic challenges awaiting them in Pre-Algebra.

Included in this booklet are the following:

- A table consisting of Middle School Math II instructional objectives with appropriate clarifying examples, cross-references to the Maryland Voluntary State Curriculum, and references to tools on the internet found in the SMART pages at www.hcpss.org/smart.
- A set of practice questions emphasizing different objectives from the Middle School Math II curriculum,
- Answers to the practice questions.

How to use this book:

- Students are requested to work in pencil and show their work in the booklet or on lined paper to accompany the booklet. They should check their answers using the key provided and, if possible, correct the work for problems solved incorrectly.

Parents/Guardians are encouraged to use the many resources made available by the Howard County Office of Mathematics and other community resources. Among these are:

- The Secondary Mathematics website <http://hcpss.org/smart>
- The Howard County Public Library's website allows free access to *Live Homework Help*, offering assistance at all levels of secondary mathematics.

ACKNOWLEDGEMENTS

A Summer Guide for Students Entering Pre-Algebra is the result of ongoing planning and development by the staff of the Howard County Secondary Mathematics Office. Roberta Girardi and Lynda Dye were the authors and editors of this guide under the direction of William Barnes.

GRADE 7 MATHEMATICS GOALS

Standard 1.0 Knowledge of Algebra, Patterns, and Functions

Instructional Objectives- Students will be able to:	MSA Assessment Limits	Clarifying Examples	SMART Resources www.hcpss.org/smart																
Complete a function table with a given two-operation rule (1.A.1.a)	Use the operations (+, -, x, ÷), numbers no more than 20 in the rule and whole numbers (0 - 500)	What are the missing values in this function table? Rule: Divide by 8 and subtract 2. <table border="1" style="margin: 5px 0;"> <tr><td style="text-align: center;"><i>x</i></td><td style="text-align: center;"><i>y</i></td></tr> <tr><td style="text-align: center;">24</td><td></td></tr> <tr><td></td><td style="text-align: center;">5</td></tr> <tr><td style="text-align: center;">96</td><td></td></tr> </table> <table border="1" style="margin: 5px 0;"> <tr><td style="text-align: center;"><i>x</i></td><td style="text-align: center;"><i>y</i></td></tr> <tr><td style="text-align: center;">24</td><td style="text-align: center;">1</td></tr> <tr><td style="text-align: center;">56</td><td style="text-align: center;">5</td></tr> <tr><td style="text-align: center;">96</td><td style="text-align: center;">10</td></tr> </table>	<i>x</i>	<i>y</i>	24			5	96		<i>x</i>	<i>y</i>	24	1	56	5	96	10	Quarter 2 Unit 4 Activities: <i>Function Machine</i> <i>Mystery</i> <i>Operations</i> <i>Number Crunchers</i>
<i>x</i>	<i>y</i>																		
24																			
	5																		
96																			
<i>x</i>	<i>y</i>																		
24	1																		
56	5																		
96	10																		
Write an algebraic expression to represent unknown quantities (1.B.1.a)	Use one unknown and one or two operations (+, -, x, ÷ with no remainders) with whole numbers, fractions with denominators as factors of 100, or decimals with no more than three decimal places (0 - 500)	Write the phrase as an algebraic expression: The quotient of a number and 4, reduced by 3. $\frac{n}{4} - 3$	Quarter 2 Unit 4 Web: <i>Flash Cards- Algebraic</i>																
Evaluate algebraic expressions (1.B.1.b)	Use one unknown and no more than two operations (+, -, x, ÷ with no remainders) with whole numbers (0 - 200), fractions with denominators as factors of 100 (0 - 100), or decimals with no more than three decimal places (0 - 100)	Example: Evaluate $2x + 4y - 3$ when $x = 3$ and $y = 2$. $2(3) + 4(2) - 3$ $6 + 8 - 3$ 11	Quarter 2 Unit 3 Activities: <i>Mathematical Scavenger Hunt</i>																

Instructional Objectives- Students will be able to:	MSA Assessment Limits	Clarifying Examples	SMART Resources www.hcpss.org/smart
Evaluate numeric expressions using the order of operations (1.B.1.c)	Use no more than 4 operations (+, -, x, ÷ with no remainders) with or without up to 2 sets of parentheses, brackets, or a division bar, with whole numbers (0 - 200), fractions with denominators as factors of 100 (0 - 100), or decimals with no more than three decimal places (0 - 100)	Simplify $\frac{3 + (15 + 3)}{2^2 + 3}$ $\frac{3 + 18}{4 + 3}$ $\frac{21}{7}$ 3	Quarter 2 Unit 3 Games: <i>Order of Operations-Matching</i> Tutorials: <i>Order of Operations</i> <i>Order of Operations-Exponents</i>
Write equations and inequalities to represent relationships (1.B.2.a)	Use a variable, the appropriate relational symbols, and one or two operational symbols (+,-,x, ÷) on either side and use whole numbers, fractions with denominators as factors of 100, or decimals with no more than three decimal places (0 - 500)	Example: T-shirt cost \$7 EACH and shipping and handling cost \$5 per order. If you wanted to spend exactly \$40, how many T-shirts can you buy? Write an equation when x = the number of T-shirts bought. Equation: $7x + 5 = 40$ The most you have to spend on T-shirts is \$40. Write an inequality to represent this situation when x = the number of T-shirts bought. Inequality: $7x + 5 \leq 40$	Quarter 2 Unit 3

PRACTICE SET 1

1. A bowling alley charges a special rate on Wednesday nights. The special rate includes a one-time charge of \$1 to rent shoes and \$3 per game. The function table below shows the relationship between the number of games a person bowls and the total cost.

Games	Cost
1	4
	13
7	22
9	

A. What is the total cost, in dollars, to bowl 9 Games?

B. How many games can you bowl if you have \$13?

2. The linear relationship shown in the table below uses the rule $y = 3x - 2$.

x	y
3	7
10	28
12	34
20	

What is the value of y when x equals 20?

3. Write the statement as an algebraic expression.

The product of 5 and a number (n), increased by 3.

4. Write the statement as an algebraic expression.

The quotient of a number (n) and 5, decreased by 6.

5. Write the statement as an algebraic expression.

6 less than a number (n).

6. Write the statement as an algebraic expression.

3 times a number (n) decreased by 6.

7. Evaluate the following expressions when $m = 8$ and $n = 7$.

A. $3m - 7$

B. $5n + 3$

C. $\frac{14}{n} - 2$

D. $\frac{m}{4} + 6$

8. Evaluate the following numeric expression.

$$6 - 3 \times 4 + 5$$

9. Evaluate the following numeric expression.

$$12(6 + 8) - 4$$

10. Evaluate the following numeric expression.

$$\frac{3 + 4 \times 5 - 2}{7}$$



11. Evaluate the following numeric expression.

$$\frac{5(9 - 3)}{2}$$

12. Amanda's long distance telephone plan charges a monthly fee of \$15.00 and \$.05 per minute for the number of minutes (m) that she uses her telephone.
- A. Write an equation to represent the situation if Amanda has exactly \$15.00 to spend next month.
- B. Write an inequality to represent the situation if Amanda has no more than \$50.00 to spend next month.
- C. Megan has a long distance telephone plan that charges a monthly fee of \$21.00 and \$.03 per minute (m). Write an equation to represent when Amanda's monthly bill will be equal to Megan's monthly bill.

GRADE 7 MATHEMATICS GOALS

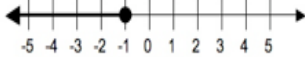
Standard 1.0 Knowledge of Algebra, Patterns, and Functions

Instructional Objectives-Students will be able to:	MSA Assessment Limits	Clarifying Examples	SMART Resources www.hcpss.org/smart
Determine the unknown in a linear equation (1.B.2.b)	Use one or two operations (+, -, x) and the unknown only once with whole numbers (0 - 500), fractions with denominators as factors of 100 (0-50), or decimals with no more than three decimal places (0-100)	Example: $\frac{x}{5} + 4 = 24$ $\frac{x}{5} = 20$ (Subtract 4 from both sides) $x = 100$ (Multiply both sides of the equation by 5)	Quarter 2 Unit 3 eTools: <i>Balance Scale</i> Videocasts: <i>Solving Equations</i> <i>BrainPOP</i>
Solve for the unknown in an inequality (1.B.2.c)	Use an inequality with one variable with a positive whole number coefficient and one operation (+, -, x, ÷) with no remainders) using whole numbers or decimals with no more than 2 decimal places (0 - 500)	Example: Solve $7x + 5 = 40$ $7x = 35$ $x = 5$ Solve $7x + 5 \leq 40$ $7x \leq 35$ $x \leq 5$	Quarter 2 Unit 3 Videocasts: <i>Solving Inequalities</i> <i>BrainPOP</i>
Identify or graph solutions of inequalities on a number line (1.B.2.d)	Use whole numbers (0-50)	Write an inequality:  $x \leq -1$ Graph an inequality $n < 4$ on a number line below. 	Quarter 2 Unit 3

Instructional Objectives-Students will be able to:	MSA Assessment Limits	Clarifying Examples	SMART Resources www.hcpss.org/ smart
Apply given formulas to a problem solving situation (1.B.2.e)	Use formulas having no more than three variables and up to two operations, with whole numbers, fractions with denominators as factors of 100, or decimals with no more than three decimal places (0 - 100)	<p>Examples:</p> <p>A rectangle has a length of 5 meters and a width of 8 meters. Find the perimeter and the area of the rectangle.</p> <p>Perimeter of a rectangle = twice the sum of the length and width $P = 2l + 2w$ $P = 2(5) + 2(8)$ $P = 10 + 16$ $P = 26$ meters</p> <p>Area of a rectangle = length times the width $A = lw$ $A = 5(8)$ $A = 40$ square meters</p>	<p>Quarter 2 Unit 3</p> <p>Videocasts <i>Solving Inequalities</i> <i>BrainPOP</i></p>

PRACTICE SET 2

1. Solve the following equation.

$$m - \frac{1}{8} = \frac{1}{2}$$

2. Solve the following equation.

$$12n + 3 = 39$$

3. Solve the following equation.

$$2.4p - 5 = 9.4$$

4. Solve the following equation.

$$\frac{1}{2}q - 4 = 5$$

5. Solve the inequality and graph the solution on a number line.

$$6k < 36$$

6. Solve the inequality and graph the solution on a number line.

$$j + 2.3 \geq 18.4$$

7. Solve the inequality and graph the solution on a number line.

$$h - 3.4 \leq 5.6$$

8. Solve the inequality and graph the solution on a number line.

$$\frac{f}{3} \leq 6$$

9. Evaluate the formula for the given values.

$$P = 2l + 2w \quad l = 5, \quad w = 6$$

10. Evaluate the formula for the given values.

$$d = rt \quad r = \frac{1}{2}, \quad t = 10$$

11. Evaluate the formula for the given values.

$$d = \frac{m}{v} \quad m = 15, \quad v = 2$$

12. Evaluate the formula for the given values.

$$A = lw \quad A = 16, \quad l = 8$$

GRADE 7 MATHEMATICS GOALS

Standard 1.0 Knowledge of Algebra, Patterns, and Functions

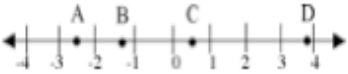
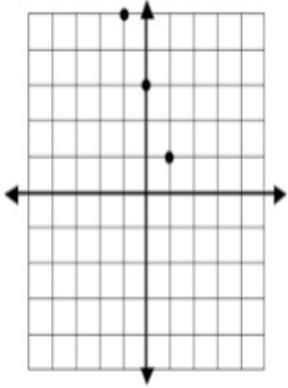
Instructional Objectives-Students will be able to:	MSA Assessment Limits	Clarifying Examples	SMART Resources www.hcpss.org/smart
Represent rational numbers on a number line (1.C.1.a)	Use rational numbers (-100 to 100)	Example: $\frac{1}{2}, 3\frac{3}{4}, -2.5, -\frac{5}{4}$ 	Quarter 1 Unit 2
Graph ordered pairs on a coordinate plane (1.C.1.b)	Use not more than 4 ordered pairs of rational numbers (-20 to 20)	Example: Graph (-1, 5), (0, 3), and (1, 1) on the coordinate grid below. 	Quarter 1 Unit 2 eTools: <i>Coordinate Plot (Simple Plot)</i> Games: <i>Maze Game</i> Tutorials: <i>Graphing on a Coordinate Plane</i>

Instructional Objectives-Students will be able to:	MSA Assessment Limits	Clarifying Examples	SMART Resources www.hcpss.org/ smart																																																
Identify and describe the change represented in a table of values (1.C.2.a)	Identify an increase, decrease, or no change	<p>Three types of changes between two variables:</p> <ol style="list-style-type: none"> 1. As one variable increases, the other variable increases also. 2. As one variable increases, the other variable decreases. 3. As one variable increases, the other variable does not change (stays constant). <p>Examples:</p> <table border="1" data-bbox="766 638 1123 743"> <thead> <tr> <th>x</th> <th>$y = 3x + 1$</th> <th>y</th> <th>(x,y)</th> </tr> </thead> <tbody> <tr> <td>0</td> <td>$y = 3(0) + 1$</td> <td>1</td> <td>(0,1)</td> </tr> <tr> <td>1</td> <td>$y = 3(1) + 1$</td> <td>4</td> <td>(1,4)</td> </tr> <tr> <td>2</td> <td>$y = 3(2) + 1$</td> <td>7</td> <td>(2,7)</td> </tr> </tbody> </table> <p>As x-values increase, y-values increase.</p> <table border="1" data-bbox="766 806 1123 911"> <thead> <tr> <th>x</th> <th>$y = -3x + 1$</th> <th>y</th> <th>(x,y)</th> </tr> </thead> <tbody> <tr> <td>0</td> <td>$y = -3(0) + 1$</td> <td>1</td> <td>(0,1)</td> </tr> <tr> <td>1</td> <td>$y = -3(1) + 1$</td> <td>-2</td> <td>(1,-2)</td> </tr> <tr> <td>2</td> <td>$y = -3(2) + 1$</td> <td>-5</td> <td>(2,-5)</td> </tr> </tbody> </table> <p>As x-values increase, y-values decrease.</p> <table border="1" data-bbox="766 974 1123 1079"> <thead> <tr> <th>x</th> <th>$y = 0x + 1$</th> <th>y</th> <th>(x,y)</th> </tr> </thead> <tbody> <tr> <td>0</td> <td>$y = 0(0) + 1$</td> <td>1</td> <td>(0,1)</td> </tr> <tr> <td>1</td> <td>$y = 0(1) + 1$</td> <td>1</td> <td>(1,1)</td> </tr> <tr> <td>2</td> <td>$y = 0(2) + 1$</td> <td>1</td> <td>(2,1)</td> </tr> </tbody> </table> <p>As x-values increase, y-values do not increase.</p>	x	$y = 3x + 1$	y	(x,y)	0	$y = 3(0) + 1$	1	(0,1)	1	$y = 3(1) + 1$	4	(1,4)	2	$y = 3(2) + 1$	7	(2,7)	x	$y = -3x + 1$	y	(x,y)	0	$y = -3(0) + 1$	1	(0,1)	1	$y = -3(1) + 1$	-2	(1,-2)	2	$y = -3(2) + 1$	-5	(2,-5)	x	$y = 0x + 1$	y	(x,y)	0	$y = 0(0) + 1$	1	(0,1)	1	$y = 0(1) + 1$	1	(1,1)	2	$y = 0(2) + 1$	1	(2,1)	Quarter 2 Unit 4
x	$y = 3x + 1$	y	(x,y)																																																
0	$y = 3(0) + 1$	1	(0,1)																																																
1	$y = 3(1) + 1$	4	(1,4)																																																
2	$y = 3(2) + 1$	7	(2,7)																																																
x	$y = -3x + 1$	y	(x,y)																																																
0	$y = -3(0) + 1$	1	(0,1)																																																
1	$y = -3(1) + 1$	-2	(1,-2)																																																
2	$y = -3(2) + 1$	-5	(2,-5)																																																
x	$y = 0x + 1$	y	(x,y)																																																
0	$y = 0(0) + 1$	1	(0,1)																																																
1	$y = 0(1) + 1$	1	(1,1)																																																
2	$y = 0(2) + 1$	1	(2,1)																																																

PRACTICE SET 3

1. Identify which point on the number line represents the following values.

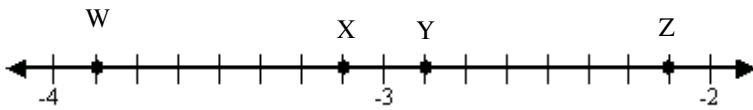

- A. $-3\frac{1}{8}$ _____
- B. $-2\frac{1}{8}$ _____
- C. $-3\frac{7}{8}$ _____
- D. $-2\frac{7}{8}$ _____

2. Graph the following points on the coordinate plane.

- A. (2, 4)
- B. (-4, 5)
- C. (-3, -5)
- D. (2, 2)

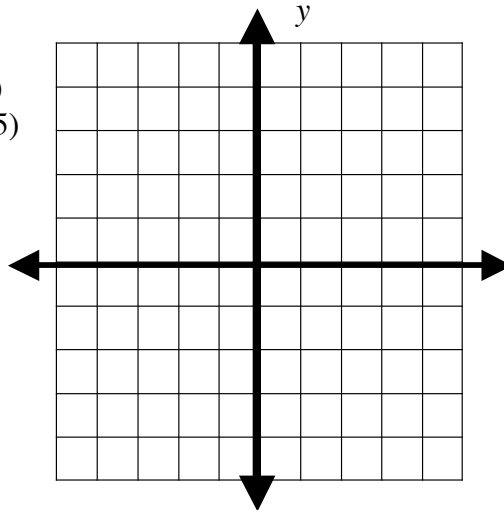

3. Identify the change in the table as increasing, decreasing or no change.

X	Y
4	10
8	8
10	6

4. Identify the change in the table as increasing, decreasing or no change.

X	Y
8	2
12	2
15	2

5. Identify the change in the table as increasing, decreasing or, no change.

X	Y
8	16
12	24
15	30

GRADE 7 MATHEMATICS GOALS

Standard 2.0 Knowledge of Geometry

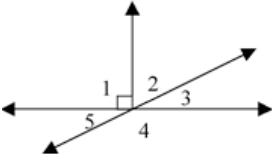
Instructional Objectives-Students will be able to:	MSA Assessment Limits	Clarifying Examples	SMART Resources www.hcpss.org/smart
Identify and describe angels formed by intersecting lines, line segments and rays (2.A.1.a)	Use vertical, adjacent, complementary, or supplementary angles (Include the angle symbol \angle m)	<p>Adjacent Angles - Two angles that have the same vertex, share a common side, and do not overlap.</p> <p>Vertical Angles - The opposite angles formed when two lines intersect. Vertical angles are <u>congruent</u>.</p> <p>Complementary Angles - The sum of the measures of two angles is 90 degrees.</p> <p>Supplementary Angles (Straight line/straight angles) - The sum of the measures of two angles is 180 degrees.</p> <p>Sample Exercise: Identify angles that are</p> <ul style="list-style-type: none"> * Supplementary * Complementary * Vertical * Adjacent  <p>Supplementary: $\angle 4, \angle 3$ $\angle 5, \angle 4$</p> <p>Complementary: $\angle 2, \angle 3$</p> <p>Vertical : $\angle 5, \angle 3$</p> <p>Adjacent: $\angle 1, \angle 2$ $\angle 2, \angle 3$ $\angle 3, \angle 4$ $\angle 4, \angle 5$</p>	Quarter 3 Unit 5

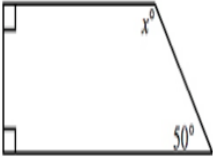
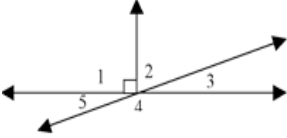
Instructional Objectives-Students will be able to:	MSA Assessment Limits	Clarifying Examples	SMART Resources www.hcpss.org/smart
Determine a missing angle measurement using the sum of the interior angles of polygons (2.A.2.a)	Use angle measures in a quadrilateral	<p>Example: Find the measure of the angle x in the figure below.</p>  <p> $90 + 90 + 50 + x = 360$ $230 + x = 360$ $x = 130^\circ$ </p>	Quarter 3 Unit 5 Web: Angles of a Polygon
Determine the measure of angles formed by intersecting lines, line segments, and rays (2.A.2.b)	Use vertical, adjacent, complementary, or supplementary angles	<p>In the diagram, the measure of $\angle 5$ is 28°. Find the measure of each of the other four angles.</p>  <p> $\angle 3 = 28^\circ$ $\angle 4 = 152^\circ$ $\angle 2 = 62^\circ$ $\angle 1 = 90^\circ$ </p>	Quarter 3 Unit 5

PRACTICE SET 4

1. Use the diagram below to identify the following angles as vertical, adjacent, complementary and/or supplementary angles.

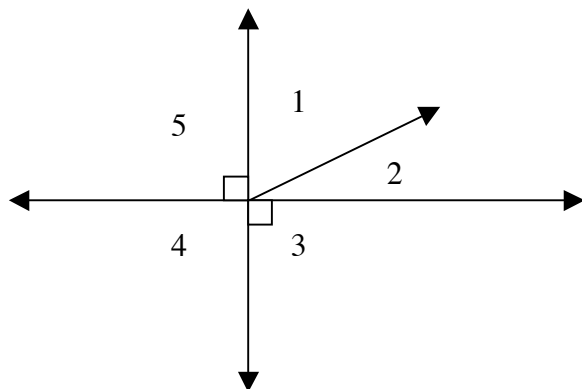

- A. $\angle 1$ and $\angle 5$ B. $\angle 1$ and $\angle 2$
C. $\angle 4$ and $\angle 5$ D. $\angle 5$ and $\angle 3$
2. Determine the missing angle measure, x .

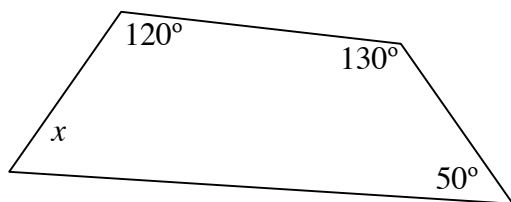

3. Determine the missing angle measure, x .

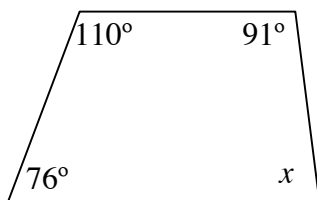

4. Use the figure below to find the following angle measure.

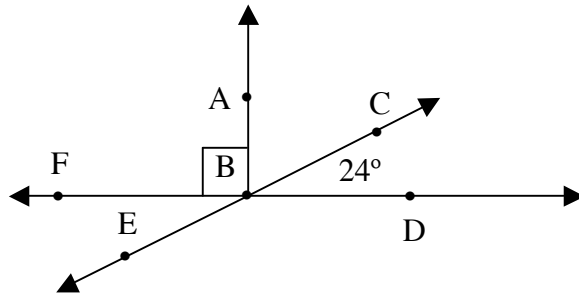



A. $\angle ABC$

B. $\angle FBE$

C. $\angle DBE$

GRADE 7 MATHEMATICS GOALS

Standard 2.0 Knowledge of Geometry

Instructional Objectives-Students will be able to:	MSA Assessment Limits	Clarifying Examples	SMART Resources www.hcpss.org/smart
Construct geometric figures using a variety of construction tools (2.C.1.a)	Construct a circle using a given line segment as the radius in whole number inches or centimeters.	Construct a circle with a given radius: Place the compass on an endpoint and the pencil on the other endpoint. Using the compass point as the center, swing the pencil around to construct the circle. 	Unit 3 Unit 5 Tutorials: <i>Perpendicular Bisectors</i>
Construct geometric figures using a variety of construction tools (2.C.1.b)	Construct a line segment congruent to a given line segment	Construct a Segment Congruent to a Given Segment: 1) Place the compass point at one endpoint and the pencil point on the other endpoint to adjust the compass length. 2) Place the compass point on the endpoint of a ray and draw an arc. Example: 	Unit 3 Unit 5 Tutorials: <i>Perpendicular Bisectors</i>

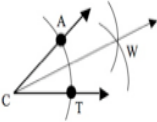
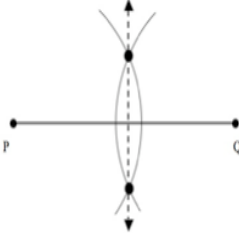
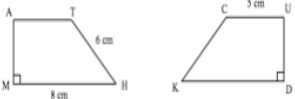
Instructional Objectives-Students will be able to:	MSA Assessment Limits	Clarifying Examples	SMART Resources www.hcpss.org/smart
Construct geometric figures using a variety of construction tools (2.C.1.c)	Construct a perpendicular bisector to a given line segment or a bisector of a given angle	<p>Construct an Angle Bisector:</p> <ol style="list-style-type: none"> 1) Place the point of your compass on C. Draw an arc that intersects the sides of $\angle C$. Label the points of intersection A and T. 2) Keeping your compass opening the same, place the point of your compass on A and the T and draw intersecting arcs in the interior of $\angle C$. Label the point of intersection W. 3) Use your straight edge to draw segment CW. <p>Example:</p>  <p>Construct a Perpendicular Bisector of a Segment:</p> <ol style="list-style-type: none"> 1) Place the point of your compass on P. Set its opening more than half the length of segment PQ. Draw an arc. 2) Keeping your compass opening the same, place the compass point on Q. Draw an arc that intersects the first arc in two places. 3) Use your straightedge to draw a line segment through the two points of intersection. <p>Example: Construct a perpendicular bisector of line segment PQ.</p> 	Unit 3 Unit 5 Tutorials: <i>Perpendicular Bisectors</i>
Determine the congruent parts of polygons (2.D.1.a)	Use the length of corresponding sides or the measure of corresponding angles and whole numbers (0 – 1000)	<p>Given: Quadrilateral MATH is congruent \cong to quadrilateral DUCK.</p>  <ul style="list-style-type: none"> • Name all corresponding angles and sides • What is the length of side CK in quadrilateral DUCK? • What is the measure of angle M in quadrilateral MATH? 	Quarter 3 Unit 5

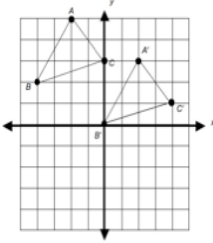
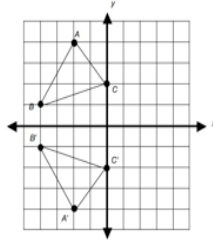
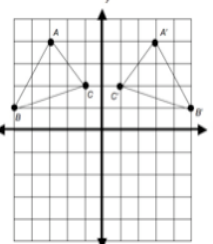
Instructional Objectives-Students will be able to:	MSA Assessment Limits	Clarifying Examples	SMART Resources www.hcpss.org/smart
Identify, describe, and plot the results of one transformation on a coordinate plane (2.E.1.a)	Identify or plot the result of one transformation (horizontal or vertical), reflection (horizontal or vertical), or rotation about the origin (90° or 180°)	<p>Example 1: Translate triangle ABC 4 units right and 2 units down.</p>  <p>Example 2: Reflect triangle ABC over x-axis.</p>  <p>Reflection over the x-axis: x-coordinates stay the same and multiply the y-coordinates by -1.</p> <p>Example 3: Reflect triangle ABC over y-axis.</p> 	Quarter 1 Unit 2 Web: <i>TransmoGrapher</i>

PRACTICE SET 5

1. Construct a circle with a radius the size of the line segment below.



2. Construct a segment congruent to the given segment EF.

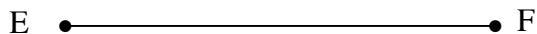

3. Construct the perpendicular bisector of segment EF.



4. Construct the angle bisector of $\angle ABC$.

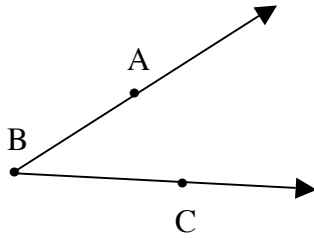

5. The two polygons below are congruent. Find the measures of the following sides and angles.
 $ABCDEFGH \cong IJKLMNOP$.

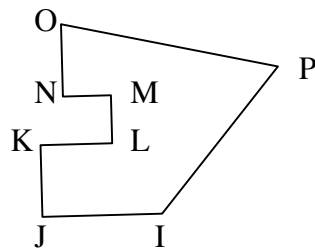
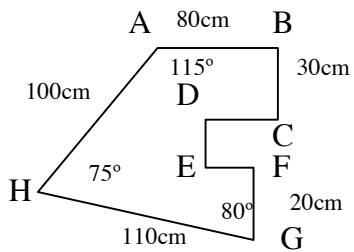

- A. $\angle OPI$ _____
 B. \overline{OP} _____
 C. $\angle JIP$ _____
 D. \overline{PI} _____

6. Plot $\triangle ABC$ where $A(-3, 1)$, $B(-1, 3)$, $C(2, 1)$ after the following transformation.

A. Translated 2 units to the right.

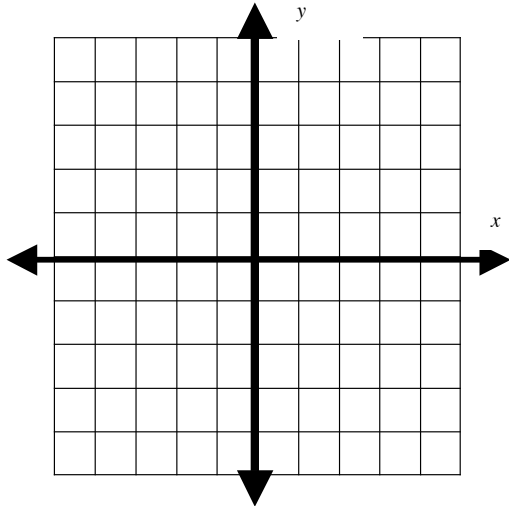

B. Rotated 90° clockwise around the origin.

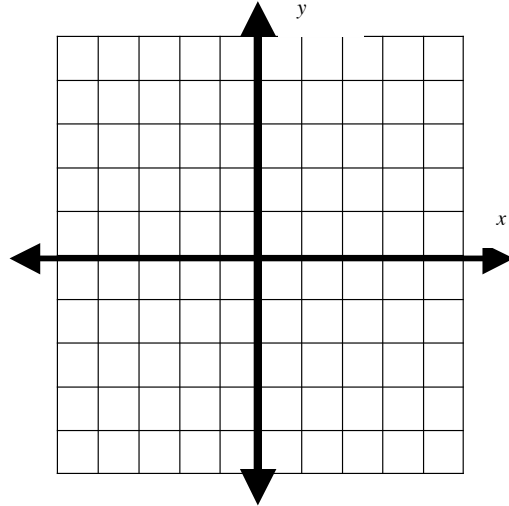

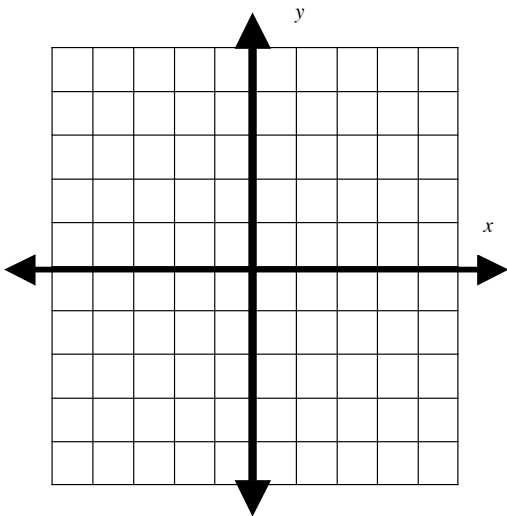

C. Reflection over the x -axis.

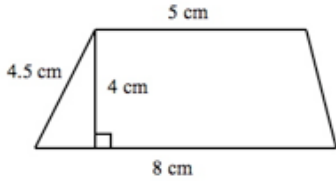
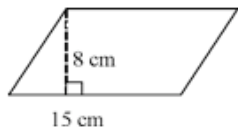
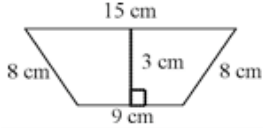

GRADE 7 MATHEMATICS GOALS

Standard 3.0 Knowledge of Measurement

Instructional Objectives- Students will be able to:	MSA Assessment Limits	Clarifying Examples	SMART Resources www.hcpss.org/smart
Estimate and determine the area of quadrilaterals (3.C.1.a)	Use parallelograms or trapezoids and whole number dimensions (0 - 1000)	<p>Example: Use the formula to find the area of this trapezoid.</p>  $A = \frac{1}{2}h(b_1 + b_2)$ $A = \frac{1}{2}(4)(5 + 8)$ $A = \frac{1}{2}(4)(13)$ $A = 26 \text{ cm}^2$ <p>Sample Exercises:</p> <p>Calculate the area of each parallelogram. Round to the nearest tenth.</p>  $A = (8)(15) = 120 \text{ cm}^2$  $A = 0.5(3)(15 + 9) = 36 \text{ cm}^2$	<p>Quarter 3 Unit 6</p> <p>Videocasts: <i>Area of Polygons</i> <i>BrainPOP</i></p> <p>eTools: <i>Area Explorer</i> <i>Shape Explorer</i></p> <p>Activities: <i>Area Formula Lab</i></p>

Instructional Objectives-Students will be able to:	MSA Assessment Limits	Clarifying Examples	SMART Resources www.hcpss.org/smart
Determine the surface area of geometric solids (3.C.1.b)	Use rectangular prisms with whole number dimensions (0 – 1000)	<p>Example: Nana is wrapping a birthday present that is 8 inches long, 3 inches wide, and 10 inches high. If Nana bought a roll of wrapping paper that is 1 foot wide and 2 feet long, does she have enough wrapping paper to wrap the birthday present?</p> <p>Surface area of the present $S = 2lw + 2lh + 2wh$ $S = 2(8)(3) + 2(8)(10) + 2(3)(10)$ $S = 48 + 160 + 60$ $S = 268$ square inches</p> <p>Area of the wrapping paper: 12 inches times 24 inches = 288 square inches.</p> <p>Since 288 square inches is larger than 268 square inches, there is enough wrapping paper to wrap the present.</p>	Quarter 3 Unit 6 eTools <i>Surface Area and Volume</i>
Determine a missing dimension for a figure using a scale (3.C.2.a)	Use a polygon with no more than 8 sides using whole numbers (0 – 1000)	<p>Larry is building a scale model of the boat in the picture. If the model is 36" long, how high is the model?</p>  <p>$\frac{15}{36} = \frac{10}{x}$ $x = 24$ inches</p>	Quarter 3 Unit 7
Determine the distance between 2 points using a drawing and a scale (3.C.2.b)	Use a scale of 1 cm=?, $\frac{1}{4}$ inch=?, or $\frac{1}{2}$ inch=?, and whole numbers (0 – 1000)	<p>New York City and Washington DC are about 250 miles apart. If a map showing both cities uses a scale $\frac{1}{4}$ in: 25 miles, how far apart will the two cities be on the map?</p> <p>Answer: 2.5 inches</p>	Quarter 3 Unit 7 eTools <i>Image Tool</i>

PRACTICE SET 6

1. Determine the area of the following quadrilaterals.

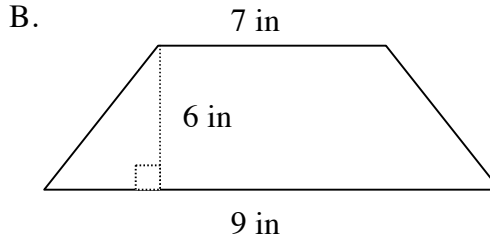
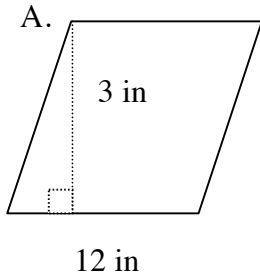

2. Determine the surface area of the rectangular prisms.

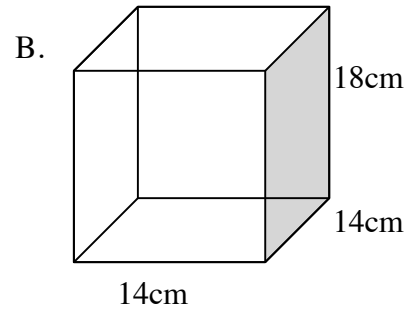
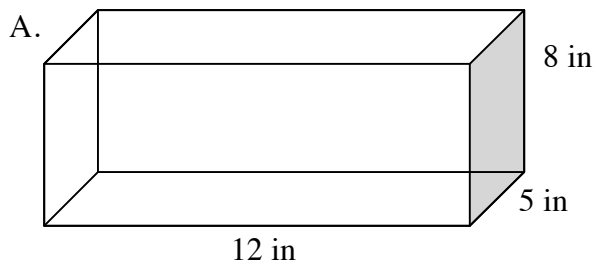

3. Determine a missing dimension of the regular figures with the given scale. Round to the nearest tenth.

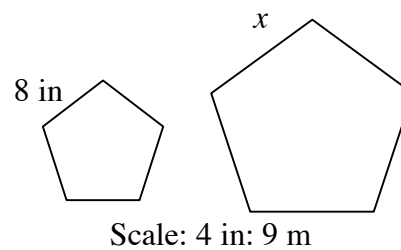
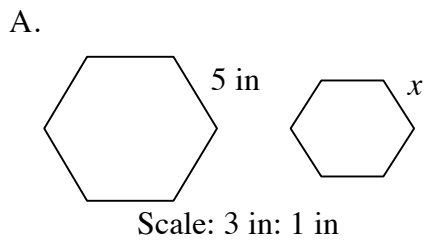

GRADE 7 MATHEMATICS GOALS

Standard 4.0 Knowledge of Statistics

Instructional Objectives-Students will be able to:	MSA Assessment Limits	Clarifying Examples	SMART Resources www.hcpss.org/ smart												
Organize and display data using back-to-back stem and leaf plots (4.A.1.a)	Use no more than 20 data points using whole numbers (0 - 99)	<p>Top Ten Home Run Hitters of 2004</p> <table style="margin-left: auto; margin-right: auto; border-collapse: collapse;"> <thead> <tr> <th style="border-right: 1px solid black; padding: 5px;">American League</th> <th style="border-right: 1px solid black; padding: 5px;"></th> <th style="padding: 5px;">National League</th> </tr> </thead> <tbody> <tr> <td style="border-right: 1px solid black; text-align: center; padding: 5px;">3 3 4 8 9</td> <td style="border-right: 1px solid black; text-align: center; padding: 5px;">3</td> <td style="text-align: center; padding: 5px;">4 5 7 7 8 9</td> </tr> <tr> <td style="border-right: 1px solid black; text-align: center; padding: 5px;">1 3</td> <td style="border-right: 1px solid black; text-align: center; padding: 5px;">4</td> <td style="text-align: center; padding: 5px;">2 2 6 9</td> </tr> <tr> <td style="border-right: 1px solid black; text-align: center; padding: 5px;">2 7</td> <td style="border-right: 1px solid black; text-align: center; padding: 5px;">5</td> <td></td> </tr> </tbody> </table> <p>Key: 3 4 = 43 home runs 4 2 = 42 home runs</p> <p>Which sentence best describes the error in the stem-and-leaf plot?</p> <p>A) The stem-and-leaf plot should have only one leaf. B) The digits on the left side of the plot are in the wrong order. C) The key for the American League is incorrect. D) The digits should be shown only once to show repeated numbers in a data set.</p> <p>Answer: B</p>	American League		National League	3 3 4 8 9	3	4 5 7 7 8 9	1 3	4	2 2 6 9	2 7	5		Quarter 4 Unit 8 Activities: <i>Stem-and-Leaf Plotter</i>
American League		National League													
3 3 4 8 9	3	4 5 7 7 8 9													
1 3	4	2 2 6 9													
2 7	5														
Recognize and analyze faulty interpretation or representation of data (4.B.1.a)	Use the choice of graphical display or the scale as leading to faulty interpretation or representation of data	Examples of Misleading Graphs: -No title -No labels on the axes or scales -Unequal intervals on a scale -Using mean for central tendency when there are outliers present	Quarter 4 Unit 8												
Determine the best choice of a data display (4.B.1.b)	Use a given data set		Quarter 4 Unit 8												
Analyze measures of central tendency to determine or apply mean, median, mode (4.B.2.a)	Use no more than 15 pieces of data for the mean or median; or 15 to 30 pieces of data for the mode, using whole numbers or decimals with no more than 2 decimal places (0 – 1000)	Determine the mean, median, and mode. 15, 21, 15, 15, 11, 25, 17, 18, 22, 11, 22, 10 Answers: Mean = 16.83 Median = 16 Mode = 15	Quarter 4 Unit 8 Games <i>Train Race</i>												

Use the data below to answer questions 3 and 4.

Justin and Jeremy have collected data from their math tests. They have decided to use a back-to-back stem-and-leaf plot to display the data.

Justin: 73%, 45%, 89%, 85%, 55%, 70%, 75%, 71%

Jeremy: 82%, 49%, 91%, 86%, 56%, 73%, 81%, 77%

3. Organize the data into a back-to-back stem and leaf plot.

4. Find the mean, median and mode of the data for both students. Round to the nearest hundredths place.

5. Organize the data below into a back-to-back stem-and-leaf plot.

Bowling Scores

Brea: 93, 85, 89, 77, 79, 90, 72

Chantel: 82, 90, 91, 86, 101, 83, 81

Use the data below to answer questions 6 and 7.

Average Weather Temperatures in Baltimore MD

Jan	Feb	Mar	Apr	May	Jun	Jul	Aug	Sep	Oct	Nov	Dec
33	37	44	54	64	73	78	76	69	57	47	37

- 6. Determine what type of graph would best represent the data.
- 7. Find the measures of central tendency of the data. Round to the nearest hundredth place.

- 8. Ann surveyed her classmates to determine their favorite pizza topping. She has put her data into a frequency table. Which type of graph would best display the results?

- A. A back-to-back stem-and-leaf plot
- B. A histogram
- C. A line graph
- D. A stem-and-leaf plot

Topping	Frequency
Plain	14
Extra Cheese	15
Pepperoni	12
Mushrooms	6
Sausage	3

- 9. Dana is drawing a graph to show how the students in her class did on their math test. Which type of graph would best display the results?
 - A. A back-to-back stem-and-leaf plot
 - B. A circle graph
 - C. A line graph
 - D. A stem-and-leaf plot

Use the data below to answer questions 10 and 11.

Money Earned While Babysitting

Saturday	1	2	3	4	5	6	7
Dollars	30	35	40	32	45	42	37

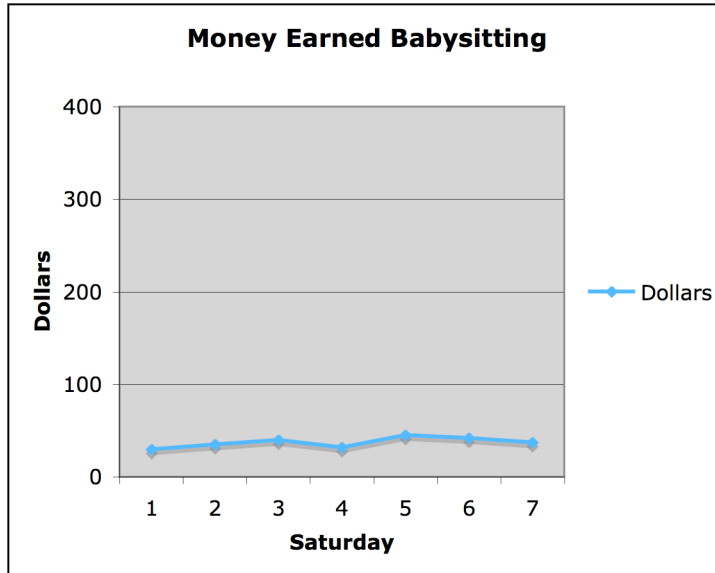

10. What part of the line graph leads to an incorrect interpretation of the data that Calvin earned the same amount of money every Saturday?
11. How can the graph be changed so that it is a better interpretation of the data?

12. The data below shows the amount of money Olivia earned on seven Saturdays.

Saturday	1	2	3	4	5	6	7
Dollars	90	50	90	90	100	50	60

The line graph below displays the data for Olivia’s earnings. Why is the graph misleading?

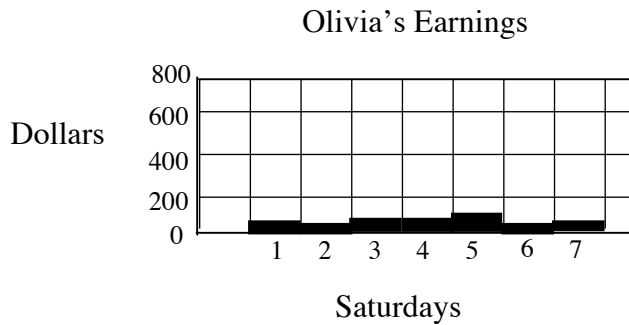

13. The graph below shows how the price of a cell phone has changed over a period of weeks. An advertisement shows this graph with the statement “The price is dropping fast.”

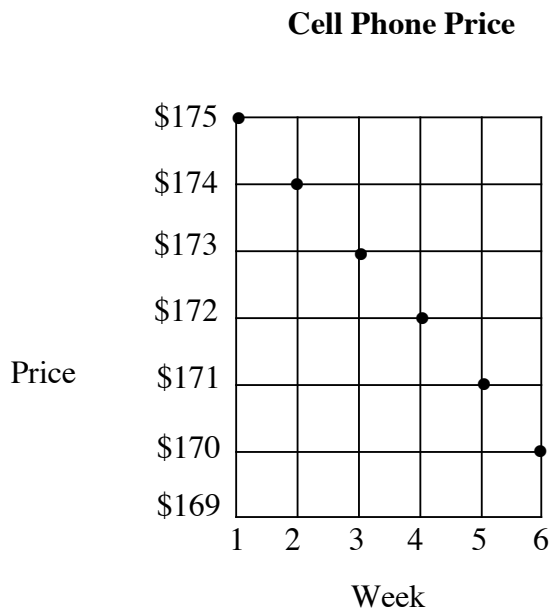

- A. Is this really true?
- B. If not why isn't it true?

GRADE 7 MATHEMATICS GOALS

Standard 5.0 Knowledge of Probability

Instructional Objectives-Students will be able to:	MSA Assessment Limits	Clarifying Examples	SMART Resources www.hcpss.org/smart
Determine the number of outcomes (5.A.1.a)	Use no more than 3 independent events with a sample space of no more than 6 outcomes in each event	<p>To determine the number of outcomes: Method 1: Make a tree diagram and find the sample space. Method 2: Use the Counting Principle.</p> <p>The counting principle states that if a first event can occur in a ways, and a second event can occur in b ways, then the two events can occur together in $a \cdot b$ ways.</p> <p>Example: A team shirt comes in 2 colors of red and black, and in 4 different sizes of small, medium, large, and extra large. How many choices of shirts are there?</p> <p>Using method 1: red small, red medium, red large, red extra large, black small, black medium, black large, and black extra large. There are 8 different choices.</p> <p>Using method 2: $2 \text{ colors} \times 4 \text{ sizes} = 8$ choices</p>	Quarter 4 Unit 9

Instructional Objectives-Students will be able to:	MSA Assessment Limits	Clarifying Examples	SMART Resources www.hcpss.org/ smart
Express the probability of an event as a fraction, a decimal, or a percent (5.B.1.a)	Use a sample space of no more than 35 outcomes and decimals with no more than 2 decimal places	<p>Example 1: You have a spinner that is divided into 8 equal sections labeled from 1 - 8. What is the probability that the spinner lands on number 3? 1/8 or 0.125 or 12.5%</p> <p>Example 2: A die is rolled and coin is tossed. What is the probability of rolling a 5 and then tossing heads? $P(5,H) = 1/6(1/2) = 1/12$</p>	<p>Quarter 4 Unit 9</p> <p>Videocasts: <i>Probability of Events BrainPOP</i></p>
Make predictions and express the probability of the results as a fraction, a decimal with no more than 2 decimal places, or a percent. (5.C.1.a)	Use results of 25 or 50	<p>38 out of 50 students preferred Park B to Park A. Predict how many of 395 students will want to go to Park B.</p> $\frac{38}{50} = \frac{x}{395}$ $x = 300.2$ <p>About 300 students will go to Park B.</p>	<p>Quarter 4 Unit 9</p> <p>eTools: <i>Dice Toss (Dice Table)</i></p>

PRACTICE SET 8

1. Determine the number of outcomes for the following events.
 - A. A six sided number cube is rolled and a coin is tossed.
 - B. A coin is tossed and an eight equally sectioned spinner is spun.
 - C. A six sided number cube is rolled and a card is chosen from a standard deck of cards.
 - D. A number cube is rolled, a coin is tossed and a four equally sectioned spinner is spun.

2. Mike's dresser has 2 blue t-shirts, 1 red t-shirt and 4 white t-shirts in a drawer. His closet he has 2 pairs of jeans, 1 pair of slacks and 3 pairs of sweat pants. To get dressed, Mike randomly chooses a t-shirt from in his dresser drawer. Then, he randomly chooses a pair of pants from his closet.
 - A. What is the probability that Mike will choose a blue shirt and a pair of jeans?
Express your answer as a fraction in simplest form.
 - B. What is the probability that Mike will choose a white t-shirt and a pair of slacks?
Express your answer as a decimal. Round to the nearest hundredth.
 - C. What is the probability that Mike will choose a red t-shirt and a pair of sweat pants?
Express your answer as a percent. Round to the nearest hundredth.

3. A number cube numbered 1 through 6 was rolled 30 times. The outcomes were recorded in the table below.

1	2	6	3	6
2	1	3	2	5
1	6	2	4	2
5	6	1	3	5
3	4	2	1	3
2	3	5	1	4

- A. Based on these results, what is the probability that a 1 will be rolled on the next rolled?
Express the probability as a fraction in simplest form.
- B. Based on the results, what is the probability that a 3 will be rolled on the next roll?
Express the probability as a decimal.
- C. Based on the results, what is the probability that a 4 will be rolled on the next roll?
Express the probability as a percent.

GRADE 7 MATHEMATICS GOALS

Standard 6.0 Knowledge of Number Relationships and Computation/Arithmetic

Instructional Objectives-Students will be able to:	MSA Assessment Limits	Clarifying Examples	SMART Resources www.hcpss.org/smart
Read, write, and represent whole numbers (6.A.1.a)	Use exponential notation with bases no more than 12 and exponents no more than 3 in standard form (0 – 1000)	Write 78,600 as an expression with exponents. $7 \times 10^4 + 8 \times 10^3 + 6 \times 10^2$ Write $8 \times 8 \times 8 \times 6 \times 6$ as an expression with exponents. $8^3 \times 6^2$	Quarter 1 Unit 1 Games: <i>Forms of Numbers</i>
Express decimals using expanded form (6.A.1.b)	Use decimals with no more than 4 decimal places (0 – 100)	Write 3.056 in expanded form. $3 + 0.05 + 0.006$	Quarter 1 Unit 1
Determine equivalent forms of rational numbers expressed as fractions, decimal, percents, and ratios (6.A.1.c)	Use positive rational numbers (0 – 100)	1) Express $1\frac{5}{8}$ as a decimal. 0.625 2) Express 55% as a fraction. $\frac{55}{100} = \frac{11}{20}$	Quarter 1 Unit 1 eTools: <i>Conversions Fraction Model (III) Fractions-Equivalent</i>
Compare, order, and describe rational numbers with or without relational symbols (<, >, =) (6.A.1.d)	Use no more than 4 fractions with denominators that are factors of 300 that are less than 101 (0-100), decimals with no more than 4 decimal places (0-100), percents (0-1000) or integers (-100 to 100)	1) Which is greater, $\frac{4}{5}$ or $\frac{7}{10}$? $\frac{4}{5} = 0.8$ $\frac{7}{10} = 0.7$ $\frac{4}{5} > \frac{7}{10}$ 2) Order from least to greatest: -3, 5, -2, 0, 3, -8, 10 -8, -3, -2, 0, 3, 5, 10	Quarter 1 Unit 1 Activities: <i>Fraction Finder Fraction Pointer Ordering Fractions (Fraction Sorter)</i> eTools: <i>Fractions – Comparing</i>

PRACTICE SET 9

1. Write $7 \times 7 \times 7 \times 6 \times 6 \times 4$ as an expression with exponents.
2. Write $9 \times 9 \times 9 \times 2$ as an expression with exponents.
3. Express 28,492 in exponential notation.
4. Write the following in standard form.
 $9 + 0.05 + 0.0006$
5. Write the following in standard form.
 $2 + 0.3 + 0.07 + 0.006$
6. Write the following in standard form.
 $1 + 0.0005$
7. Write the following in expanded form.
4.75
8. Write the following in expanded form.
5.178
9. Express 63% as a fraction.
10. Are $\frac{6}{12}$ and $\frac{18}{36}$ equivalent? Explain your answer.

11. What % is equivalent to 0.083?

12. List the following numbers in order from least to greatest.

0.724 72% $\frac{14}{35}$ $\frac{1}{4}$ 51%

13. If you arranged the following numbers in order from least to greatest, which one would be the greatest?

0.16 14% $\frac{1}{5}$ $\frac{3}{8}$ 0.25

GRADE 7 MATHEMATICS GOALS

Standard 6.0 Knowledge of Number Relationships and Computation/Arithmetic

Instructional Objectives-Students will be able to:	MSA Assessment Limits	Clarifying Examples	SMART Resources www.hcpss.org/smart
Add, subtract, multiply, divide integers (6.C.1.a)	Use one operation (-100 to 100)	Evaluate the expressions: $-15 \div 3 = -5$ $-5 - 8 = -13$ $-9 + 1 = -8$ $-3 \times -7 = 21$	Quarter 1 Unit 2 eTools: <i>Number Line</i> <i>Bounce</i> Games: <i>Adding Signed (Integer) Numbers</i> <i>Adding, Subtracting, Multiplying or Dividing Signed (Integer) Numbers</i> <i>Multiplying or Dividing Signed (Integer) Numbers</i> <i>Subtracting Signed (Integer) Numbers</i> Videocasts: <i>Adding and Subtracting Integers</i> <i>BrainPOP</i>

Instructional Objectives-Students will be able to:	MSA Assessment Limits	Clarifying Examples	SMART Resources www.hcpss.org/ smart
Add, subtract, and multiply positive fractions and mixed numbers (6.C.1.b)	Use no more than 2 operations and positive fractions or mixed numbers with denominators as factors of 300 less than 101 (0 - 2000)	$2\frac{1}{4} + 5\frac{5}{6} =$ $2\frac{3}{12} + 5\frac{10}{12} =$ $7\frac{13}{12} = 8\frac{1}{12}$ $7\frac{1}{8} - 4\frac{3}{4} =$ $7\frac{1}{8} - 4\frac{6}{8} =$ $6\frac{9}{8} - 4\frac{6}{8} = 2\frac{3}{8}$ $3\frac{2}{7} \times 1\frac{1}{13} = \frac{23}{7} \times \frac{14}{13}$ $\frac{46}{13} = 3\frac{7}{13}$	Quarter 1 Unit 1 eTools: <i>Fractions – Adding</i> <i>Fractions – Rectangle</i> <i>Multiplications</i> Tutorials: <i>Adding Two Fractions</i> <i>Multiplying 2 Fractions</i>
Calculate powers of integers and square roots of perfect square whole numbers (6.C.1.d)	Use exponents of no more than 3 for integers (-10 to 20) or square roots of perfect square whole numbers (0-100)	Simplify $2^3 = 2 \times 2 \times 2 = 8$ $(-2)^3 = (-2)(-2)(-2) = -8$ $\sqrt{144} = 12$	Quarter 2 Unit 3 Games: <i>Square Roots</i> <i>Tic-Tac-Toe</i> <i>Tic-Tac-Toe: Easy Problems</i> <i>Tic-Tac-Toe: Hard Problems 1</i> <i>Tic-Tac-Toe; Hard Problems 2</i> <i>Tic-Tac-Toe; Medium Problems</i> <i>Tic-Tac-Toe; Super Brain Problems</i>

PRACTICE SET 10

1. Evaluate the following expressions

A. $-2 + 11$

B. $-11 + 2$

C. $-11 + -2$

2. Evaluate the following expressions

A. $-4 - 8$

B. $-4 - (-8)$

C. $4 - 8$

3. Evaluate the following expressions

A. $-2(11)$

B. $2(-11)$

C. $-2(-11)$

4. Evaluate the following expressions

A. $-10 \div -2$

B. $-10 \div 2$

C. $10 \div -2$

5. Add. Simplify your answer if needed.

$$5\frac{1}{2} + 3\frac{2}{3}$$

6. Add. Simplify your answer if needed.

$$\frac{6}{7} + \frac{3}{5}$$

7. Add. Simplify your answer if needed.

$$1\frac{1}{2} + 6\frac{2}{3}$$

8. Lydia had $2\frac{1}{5}$ yards of blue fabric and $1\frac{2}{3}$ yards of green fabric. How much fabric did she have altogether?

9. Subtract. Simplify your answer if needed.

$$9\frac{3}{4} - 3\frac{2}{3}$$

10. Subtract. Simplify your answer if needed.

$$\frac{5}{7} - \frac{3}{5}$$

11. Subtract. Simplify your answer if needed.

$$6\frac{3}{8} - 2\frac{1}{4}$$

12. Jariff cut an eight-foot piece of wood into two pieces. One piece was $3\frac{1}{8}$ feet long and the other piece was $4\frac{7}{8}$ feet long. How much longer was the longest section?

13. Multiply. Simplify your answer if needed.

$$2\frac{3}{4} \times 3\frac{2}{3}$$

14. Multiply. Simplify your answer if needed.

$$\frac{5}{6} \times \frac{4}{25}$$

15. Multiply. Simplify your answer if needed.

$$1\frac{2}{3} \times 7\frac{2}{5}$$

16. Divide. Simplify your answer if needed.

$$\frac{2}{3} \div \frac{4}{5}$$

17. Divide. Simplify your answer if needed.

$$5 \div 3 \frac{1}{3}$$

18. Divide. Simplify your answer if needed.

$$4 \frac{2}{5} \div 2 \frac{4}{3}$$

19. Simplify the following expressions.

A. $(-4)^2$

B. 7^2

C. $\sqrt{64}$

D. $\sqrt{25}$

GRADE 7 MATHEMATICS GOALS

Standard 6.0 Knowledge of Number Relationships and Computation/Arithmetic

Instructional Objectives-Students will be able to:	MSA Assessment Limits	Clarifying Examples	SMART Resources www.hcpss.org/ smart
Use the laws of exponents to simplify expressions (6.C.1.e)	Use the rules of exponents (power times power or power divided by power) with the same whole number base (0-100) and exponents (0-10)	Examples: $3^3 \times 3^2 = 3^5$ $\frac{3^{10}}{3^7} = 3^3$	Quarter 2 Unit 3
Identify and use the properties of addition and multiplication to simplify expressions (6.C.1.f)	Use the commutative property of addition or multiplication, associative property of addition or multiplication, or the identity property for one or zero with whole numbers (0-100)	Commutative: $3 + 5 = 5 + 3$ Associative: $5 + (6 + 7) = (5 + 6) + 7$ Identity for 0: $6 + 0 = 6$ Identity for 1: $7 \times 1 = 7$	Quarter 1 Unit 1 Videocasts: <i>Associative Property Brainpop</i> <i>Commutative Property Brainpop</i> Web: <i>Properties of Real Numbers Flashcards</i>
Determine approximate sums, differences, products, and quotients (6.C.2.a)	Use no more than 3 positive rational numbers (0 – 1000)	About how much is $88 \div 10.5$? 8	Quarter 1 Unit 1 Activities: <i>Estimation</i> Games: <i>Estimate!</i>
Determine equivalent ratios (6.C.3.a)	Use denominators as factors of 300 but less than 101 and whole numbers (0 – 100)	Are the following ratios equivalent? $\frac{64}{80}$ and $\frac{20}{25} = \frac{4}{5}$ and $\frac{4}{5}$ They are equivalent.	Quarter 3 Unit 7

Instructional Objectives-Students will be able to:	MSA Assessment Limits	Clarifying Examples	SMART Resources www.hcpss.org/ smart
<p>Determine and use rates, unit rates, and percents as ratios in the context of a problem (6.C.3.b)</p>	<p>Use whole numbers (0 – 1000)</p>	<p>A 24 oz. carton of ice cream costs \$4.00. How much is that per oz?</p> <p>$4 \div 24 = .17.$</p> <p>There are 13,640 registered voters in Bruce’s town. In the last election, 65% of the registered voters voted. How many people voted?</p> <p>$13,640 \times .65 = 8866$</p>	<p>Quarter 3 Unit 7</p> <p>Web: <i>Unit Ratio</i></p> <p><i>Calculator</i></p> <p>Activities: <i>Figure This! How Much Does It Cost?</i></p> <p><i>Figure This!</i></p> <p><i>Majority Vote</i></p> <p>Games: <i>Revisewise</i></p> <p><i>Percentages</i></p> <p>Web: <i>Discount Calculator</i></p>

PRACTICE SET 11

1. Simplify.
 $2^2 \times 2^3$

2. Simplify.
 $\frac{3^{10}}{3^8}$

3. Simplify
 $4^{12} \times 4^6$

4. Which property does the example show? $26 + (13 + 7) = (26 + 13) + 7$

- A. Additive inverse property
- B. Commutative property of addition
- C. Associative property of addition
- D. Identity property of addition

5. What number sentence is true?

- A. $a - b = b - a$
- B. $a + b = b - a$
- C. $a - (b - c) = (a - b) - c$
- D. $a + (b + c) = (a + b) + c$

6. What number sentence is true?

- A. $a + 1 = a$
- B. $a \times b = b \times a$
- C. $a \div b = b \div a$
- D. $a \times 1 = 0$

7. What number would make this equation true?

$$30 + \square = 30$$

8. What is the best estimate of 9% of 220?

9. What is the best estimate of $3.65 \div 4$?

10. On Friday, 915 people went to a school's soccer game. On Saturday, 788 people attended. What is the approximate difference in the attendance of both games?

11. Which ratio is equal to 48:50?

A. 2:5

B. 7:10

C. 96:180

D. 144:150

12. A restaurant used 50 cups of flour and 15 cups of sugar. What was the ratio of flour to sugar in lowest terms?

13. Are the following ratios equivalent?

$$\frac{15}{35} \text{ and } \frac{20}{45}$$

14. Forty-two people visited a craft store between 8:00 am and 11:00 am. How many people is this per hour?

15. Joanne is making banana bread using a recipe that calls for one pound of ripe bananas. The market has bananas on sale for 3 pounds for \$0.59. How much will Joanne pay for one pound of bananas? Round to the nearest cent.
- A. \$0.18
 - B. \$0.19
 - C. \$0.20
 - D. \$0.21
16. Mario is practicing a song on his piano. In 30 minutes he can play the song 8 times. At this rate, how many times can he play the song in 60 minutes?

Use the information in the box below to answer items 17 and 18.

CD Player Regular Price: \$49.99 Sales Tax: 5%
--

17. What is the sale price during a 30% off sale, excluding sales tax? Round to the nearest cent.
18. Calculate the cost of a CD player that is not on sale, including tax. Round to the nearest cent.
19. How much is a 35% discount on a bicycle that originally costs \$149? Round to the nearest cent.
- A. \$521.50
 - B. \$143.78
 - C. \$96.85
 - D. \$52.15

ANSWER KEY

Practice Set 1:

- | | |
|---|-------------------------|
| 1. A. 28 | B. 4 |
| 2. 58 | 3. $5n + 3$ |
| 4. $\frac{n}{5} - 6$ | 5. $n - 6$ |
| 6. $3n - 6$ | |
| 7. A. 17 B. 38 C. 0 D. 8 | |
| 8. -1 | 9. 164 |
| 10. 3 | 11. 15 |
| 12. A. $0.05m + 15 = 25$ | B. $0.05m + 15 \leq 50$ |
| C. $0.03m + 21 = 0.05m + 15$ | |

Practice Set 2:

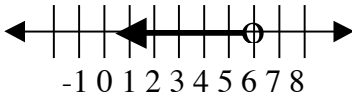
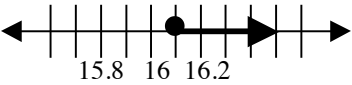
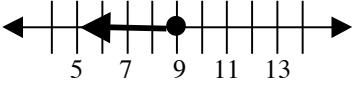
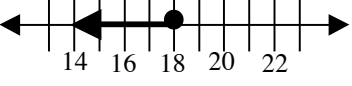
- | | |
|----------------------|---|
| 1. $m = \frac{5}{8}$ | 2. $n = 3$ |
| 3. $p = 6$ | 4. $q = 18$ |
| 5. $k < 6$ |  |
| 6. $j \geq 16.1$ |  |
| 7. $h \leq 9.0$ |  |
| 8. $f \leq 18$ |  |
| 9. $p = 22$ | 10. $d = 5$ |
| 11. $d = 7.5$ | 12. $w = 2$ |

Practice Set 5:

1.

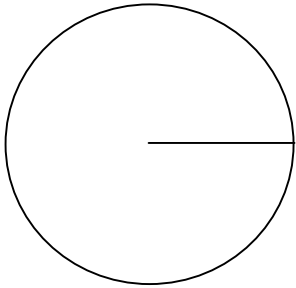

2.



3.

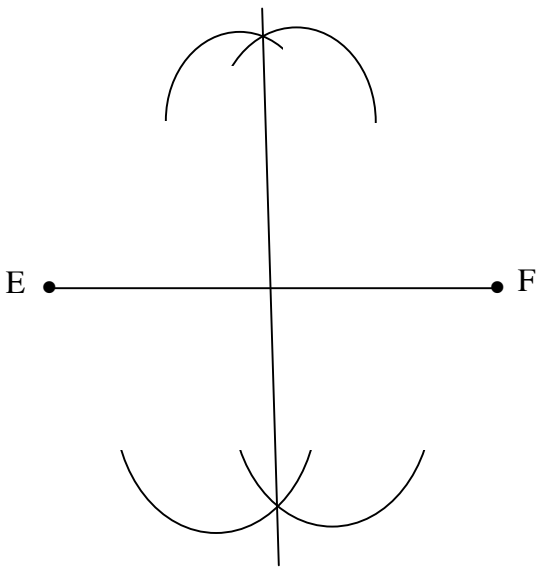

4.

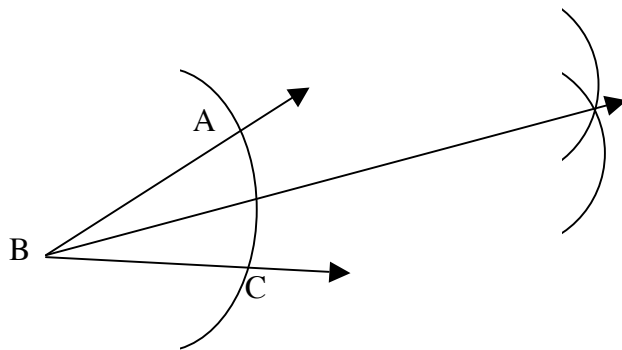

5. A. 75° B. 110 cm C. 115° D. 100 cm

6.

A. Translated 2 units to the right.

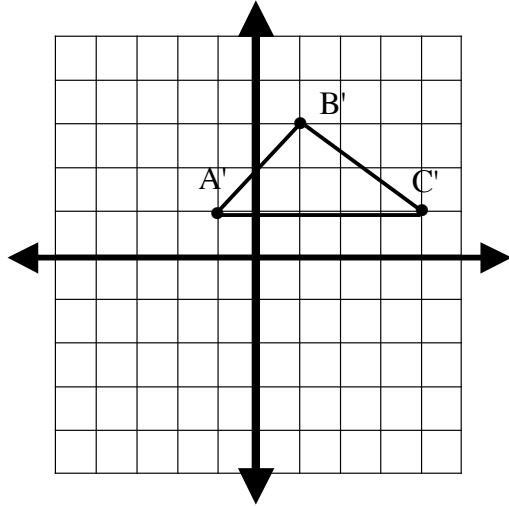

B. Rotated 90° clockwise around the origin.

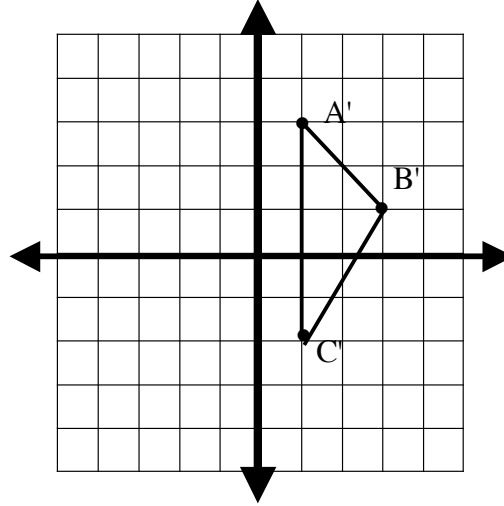

C. Reflection over the x -axis.

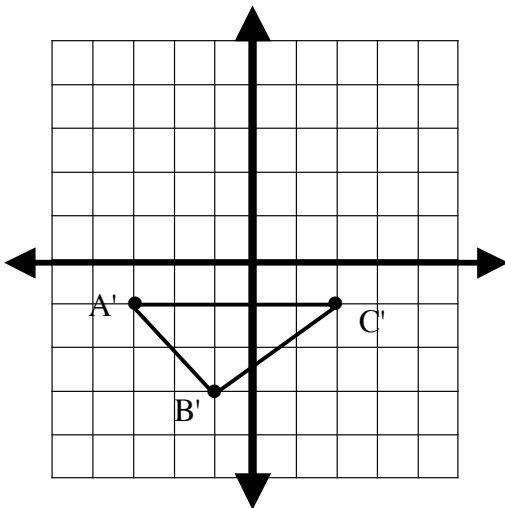

Practice Set 6:

- | | | | | |
|----|----|--------------------|----|---------------------|
| 1. | A. | 36 in^2 | B. | 48 in^2 |
| 2. | A. | 392 in^2 | B. | 1400 in^2 |
| 3. | A. | 1.7 in | B. | 18 in |
| 4. | A. | 20 miles | B. | 1 cm |

Practice Set 7:

1.

American League		National League
8	2	
5 5 1 1	3	4 4 4 6
6	4	0 7
4	5	0

Key 1 | 3 | 4

Means 31 and 34

2. American League: Mean 37.14 Median 35 Mode 31 and 35
 National League: Mean 39.29 Median 36 Mode 34

3.

Justin		Jeremy
5	4	9
5	5	6
	6	
5 3 1 0	7	3 7
9 5	8	1 2 6
	9	1

Key 0 | 7 | 3

Means 70 and 73

4. Justin: Mean 70.38 Median 72 Mode none
 Jeremy: Mean 74.38 Median 79 Mode none

5.

Brea		Chantal
9 7 2	7	
9 5	8	1 2 3 6
3 0	9	0 1
	10	1

Key 5 | 8 | 1

Means 85 and 81

6. Line graph

7. Mean 55.75 Median 55.5 Mode 43

8. B 9. D 10. The y-axis (Dollars)

11. The intervals on the y-axis (Dollars) should be much closer together.

12. The intervals on the y-axis should be much closer together.

13. A. No B. In six weeks the price of the cell phone only dropped by \$5.

Practice Set 8:

1. A. 12 B. 16 C. 312 D. 48

2. A. $\frac{2}{21}$ B. 0.10 C. 7%

3. A. $\frac{1}{5}$ B. 0.2 C. 10%

Practice Set 11:

- | | | | |
|-----|------------|-----|------------------|
| 1. | 2^5 | 2. | 3^2 |
| 3. | 4^{18} | 4. | C |
| 5. | D | 6. | B |
| 7. | 0 | 8. | About 22 |
| 9. | About 0.91 | 10. | About 100 people |
| 11. | D | 12. | $\frac{10}{3}$ |
| 13. | No | 14. | 14 |
| 15. | 20¢ | 16. | 16 |
| 17. | \$34.99 | 18. | \$52.49 |
| 19. | D | | |